

Sipario electronics and technology

With its featured command and safety functions, the new Sipario electronics add many special details, for total operator control and optimal service levels.

The Encoder-based button means high-level performance and autonomous thrust control based on the working temperature of the motor; which means constant speed of movement, even under extremely intensive-use conditions.

All of the functionalities are standard issue and accessible via the, cable or wireless, functions selector; to command all the modes on the control panel, such as: two-way, one-way, door blocked open, door blocked closed, and partial opening of the gate leaves. Another one of the standard functions is the so-called "Chemist's" mode; which limits door opening while blocking it, and all via push button.

USB port for connection built-into the function selector, for downloading and uploading configurations from one door another.

Wireless functions selector for remotely managing and controlling every functionalities.

"Clock" module uses a daily timer to control and schedule functions.

Coupled connections and "compass" function, all standard on the control panel connecting two automations via a tri-polar cable.

Dedicated connection for the 001TSP00 proximity reader and for digital keypads of the 001S5000 - 001S6000 - 001S7000 (max. 25 users overall).

Radio commands are possible via the snap-in receiver. The system can control up to 8 automatic doors using just one Tam or Top or Atomo-series transmitter, or, via the 001S9000 radio-digital keypad (max. 25 overall users).





KIT SOLUTION: USER FRIENDLY AND ALWAYS READY FOR DELIVERY!

The Sipario kit is pre-cabled and, with just a few, simple operations, lets you set-up an operator designed specifically around customers' needs: quickly and competitively.

DEDICATED PROFILES FOR BUILDING DOOR-LEAVES.

A vast range of aluminium profiles, for building framed and glass door-leaves, make Sipario the complete solution, that also boasts refined and rational aesthetics.

The Sipario range

Complete operators with 24 V DC gearmotors	
001SIPARIO1	Operator for one sliding-door leaf weighing up to 100 Kg and of two end caps.  
001SIPARIO2	Operator for two sliding-door leaves weighing up to 100 Kg per leaf and of two end caps.  
Accessories	
001SIPP	Wall-mounting profile.
001SIPTR	Anodized-aluminium beam profile.
001SIPC	Natural anodised aluminium carter, complete with dust strip and hinges.
001SIPCG	Non-finish aluminium carter, complete with dust strip and hinges.
001SIPA02	Electro-lock complete with pull-cord and release lever.
001SIPA01	Electric anti-panic device complete with two 12 V - 1.2 Ah batteries.
001SIPA03	Functions selector.
001SIPA04	Transceiver functions selector switch (must have item 001SIPA05).
001SIPA14	Wall support for transceiver functions selector.
001SIPA05	Radio receiver complete with antenna.
001SIPA06	Clock card to set timer functions - such as timed openings and closings - (must have at least one functions-selector 001SIPA03 or 001SIPA04).
001SIPA07	Extra pull-cord release L = 5 m
001SIPA08	Double pair of wall-box mounted infrared beam micro-photocells, 24 V AC - DC with 7 m range, complete with L = 6 m screened cable.
001SIPA09	Double pair of wall-box mounted infrared beam micro-photocells, 24 V AC - DC with 7 m range, complete with L = 6 m screened cable.

Dimensions (mm)

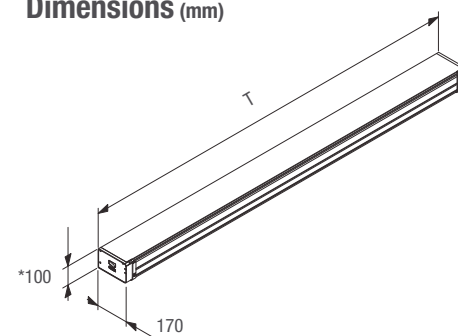

* H Beam Height = 110 mm with 001SIPP accessory.

Dimensions

MODEL	SIPARIO 1	SIPARIO 2
T min. length of beam (mm)	1286	1286
T max. length of beam (mm)	6726	6726

* H Beam Height = 110 mm with 001SIPP accessory. 

Limits to use

MODEL	SIPARIO1	SIPARIO2
Min. width of door-leaf (mm)	630	920 (460 + 460)
Max. width of door-leaf (mm)	3350	3350 (1675 + 1675)
Max. weight of door-leaf (Kg)	* 100	100 + 100



* SIPARIO1 can also move single door leaves weighing up to 200 Kg by adding two castor wheels.

Technical specifications

Type	SIPARIO1	SIPARIO2
Power supply (V - 50/60 Hz)	230 AC ± 10%	230 AC ± 10%
Motor power supply (V - 50/60 Hz)	24 DC	24 DC
Power draw (A)	5.3	5.3
Max. power rating	220	220
Thrust (Kg)	5	5
Duty cycle (%)	INTENSIVE USE	INTENSIVE USE
Max. manoeuvre speed (cm/s)	80	80
Operating temperature (°C)	-20 ÷ +55	-20 ÷ +55





Sipario

AUTOMATIC SLIDING DOOR FOR LEAVES WEIGHING UP TO 100 KG



SEE CAME'S LATEST from your licensed dealer or on came.com

© Came - K0EPIFCENOMP1E11 - REV1 - EN - 08/2011



CAME cancelli automatici S.p.A.
via Martiri della Libertà, 15
31030 Dossan di Casier
Treviso - Italy
Tel. (+39) 0422 4940
Fax (+39) 0422 4941
info@came.it
www.came.com

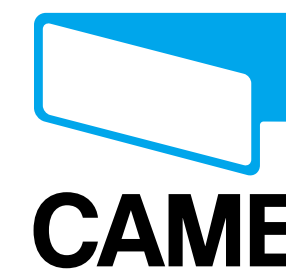

Sipario

Enter technology.

AUTHENTIC ITALIAN QUALITY.

The 100% Made in Italy original trademark testifies that the full range of Came automated products, stem from a quality productive process, designed to generate technologically reliable and efficient products. These undergo wear-and-tear tests simulating 10-15 years of intensive use, plus resistance to extreme temperature tests, and operating within electro magnetic interferences tests. It means prestige and confidence for those installing it, and safety and peace-of-mind to those using it.



Sipario is Came's latest solution for sliding automatic doors. The cutting-edge technologies and materials make it so that multiple automated entrance variations are possible - even those involving more complex conditions. This is the ideal operator, for either single applications or large commercial and service sector solutions.

The reasons to choose Sipario

10 CENTIMETRES OF SUPER-FINE TECHNOLOGY.

Easy to install, the new Sipario automatic door provides top-level, hi-tech solutions and service, in just 10 cm (the height of the beam profile). A refined, intelligently engineered system, which blends into the most diverse conditions of use and brings you superior applicative flexibility: from single to commercial and service sector systems. With Sipario **you always get the right solution!**

STRENGTHS:

Minimum overall dimensions, thanks to the limited height (just 10 cm) of the bearing profile, so it's easy to fit, even when the main beam is low or with false ceilings.

The electronics that communicate, via the built-in USB connection in the function selector, let you download and upload the automation settings, making it easier to configure in systems with multiple doors.

And with wireless programming, thanks to a new command selector switch, which allows you to manage the door's functions remotely and wirelessly. In fact, all movement parameters can be adjusted, without acting directly on the control panel, for on-the-spot management of installation, configuration and maintenance operations.



FASTENING THE DOOR TO THE MAIN BEAM IS MADE EASIER BY THE OPPOSITE MOUNTING PROFILE. (the minimum height of the main beam with this accessory is 11 cm) .

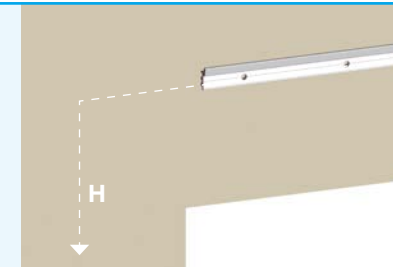

Position the mounting profile at the proper height with respect to the wall.

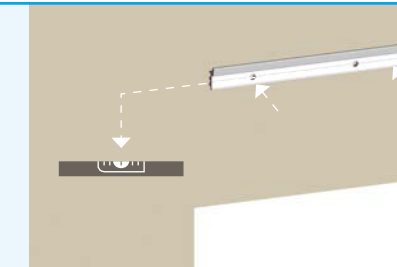

Align the profile horizontally and fasten it to the support using all of the holes.

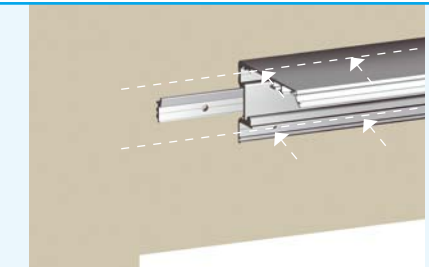

Place the beam on the assembly profile and fasten it to the support using the four holes on the ends.

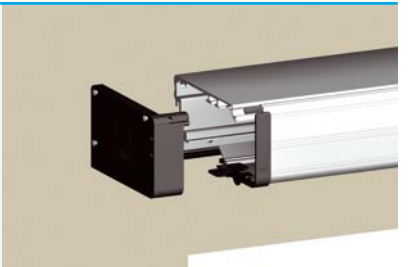

Complete assembly by fastening the cart and end caps.

THE RELEASE LEVER IS BUILT-INTO THE SIDE COVER.



THE RELEASE LEVER, IS ALWAYS HANDY!

The built-in mechanical release system simplify door-releasing manoeuvres in emergency situations. For single entrances, a second release point can be connected, and placed outside the door.