

Ensor SH5

Ø 45 mm



Main characteristics

- 230 V AC - 50 Hz
- Wired electronic limit switch
- Obstacle detector in both directions



Shutters



Obstacle detection



Wired



Full automatic

Specific features

ESPECIALLY FOR SHUTTERS.

Universal head for applying any type of anchoring plate.

Inversion of the direction of operation in both directions if an obstacle is detected.

Connection cable included: 2.5 m.

FULL AUTOMATIC setting up to 20 Nm.

Control accessories



PUSHBUTTON PANELS

Buttons and switches.



001YE0124

Special accessory for programming and power supply.



detail of the output shaft



special pulley

Ensor SH5

Ø 45 mm



KDEP#TEN3H4AS112

Dimensions (mm)

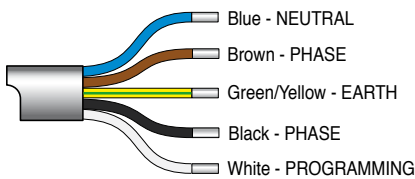
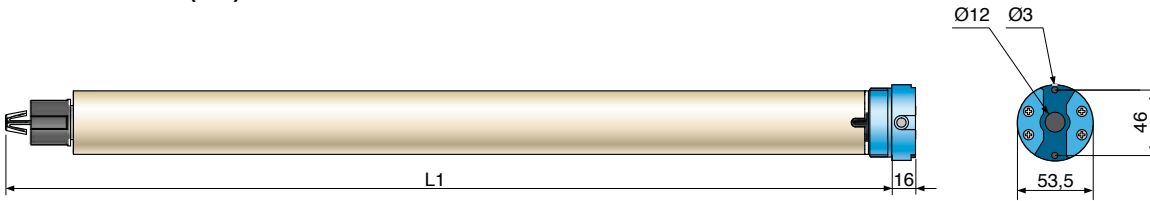

Ensor SH5



CODE

001Y5010A151ENS

001Y5020A151ENS

001Y5030A151ENS

001Y5040A121ENS

Technical information

Torque (Nm)	10	20	30	40
Speed RPM (turns/min)	15	15	15	12
Hoisted weight (kg)*	18	36	55	74
Limit switch turns (turns)	-	-	-	-
Duration of operation (min)	4	4	4	4
Power draw (A)	0.48	0.69	0.87	0.99
Power (W)	113	161	200	228
Protection rating (IP)	44	44	44	44
Tube length (mm) = L1	604	604	654	654
Weight (kg)	2.21	2.29	2.6	2.7
Package dimensions (mm)	660x80x80	660x80x80	710x80x80	710x80x80
Weight of packaged motor (kg)	2.47	2.64	3.0	3.1
Cable length (m)	2.5	2.5	2.5	2.5
Cable cross-section (mm) ²	5G 0.75	5G 0.75	5G 0.75	5G 0.75

* Load calculated for 50 mm roller.

Special adaptors for the SH version

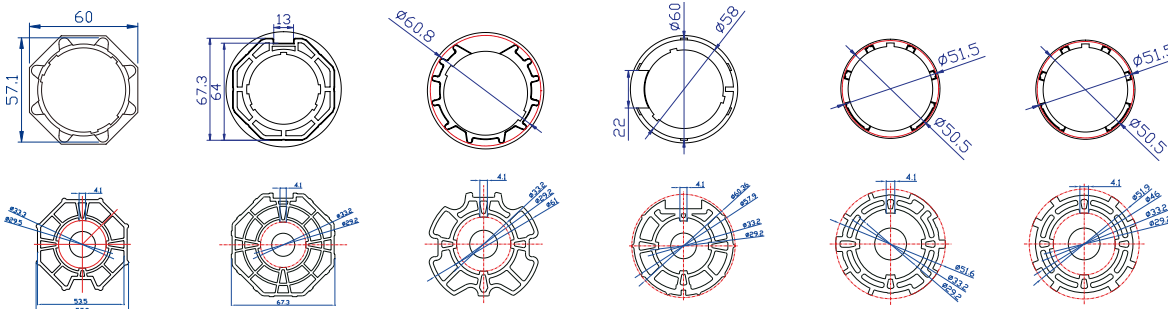

001YK5104S

Octagonal
59 x 0.7 mm

001YK5105S

Octagonal
70 x 1.2 mm

001YK5112S

Z.F. round
64 x 1 mm

001YK5115S

DEPRAT ogive
62 x 0.6 mm

001YK5116S

Z.F. round
54 x 0.5 mm

001YK5134S

DEPRAT round
53 x 0.6 mm

PRODUCTS



www.came.com